

SHF Horizontal Shaft Support

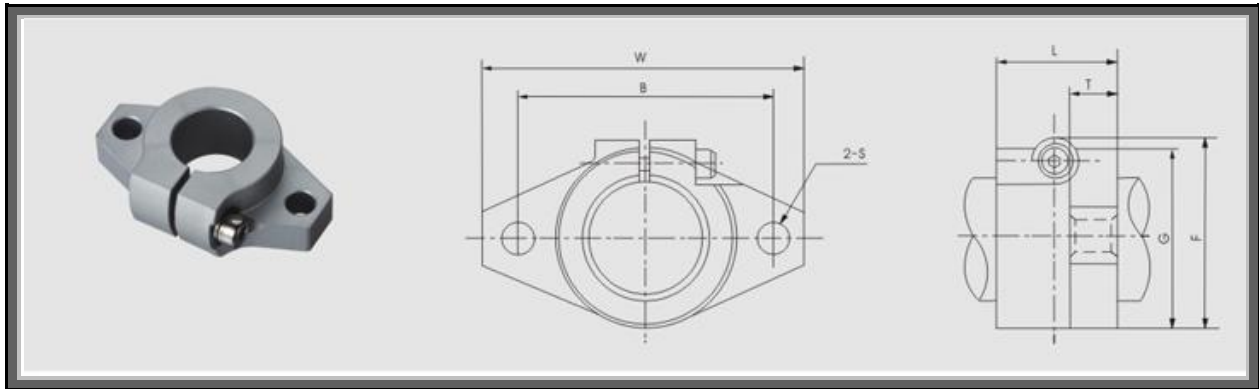

Model No.	SHAFT DIAMETER	MAIN DIMENSIONS							DESIGNATION OF CLAMPING BOLT	DESIGNATION OF MOUNTING BOLT	WEIGHT (Kg)
		W	L	T	F	G	B	S			
SHF3	3	43	10	5	24	20	32	5.5	M4	M5	0.013
SHF4	4	43	10	5	24	20	32	5.5	M4	M5	0.013
SHF5	5	43	10	5	24	20	32	5.5	M4	M5	0.013
SHF6	6	43	10	5	24	20	32	5.5	M4	M5	0.013
SHF8	8	43	10	5	24	20	32	5.5	M4	M5	0.013
SHF10	10	43	10	5	24	20	32	5.5	M4	M5	0.013
SHF12	12	47	13	7	28	25	36	5.5	M4	M5	0.020
SHF13	13	47	13	7	28	25	36	5.5	M4	M5	0.020
SHF16	16	50	16	8	31	28	40	5.5	M4	M5	0.027
SHF20	20	60	20	8	37	34	48	7	M5	M6	0.040
SHF25	25	70	25	10	42	40	56	7	M5	M6	0.060
SHF30	30	80	30	12	50	46	64	9	M6	M8	0.110
SHF35	35	92	35	14	58	50	72	12	M8	M10	0.380
SHF40	40	102	40	16	67	56	80	12	M10	M10	0.510
SHF50	50	122	50	19	83	70	96	14	M12	M12	0.890